

Quick-action contact head Type KK

Self-clamping Quick-action contact head for electroplating racks

Table of Dimensions in mm

Type	KK 32	KK46
B	32	46
L	150	240
D	57	74
a1	10	10
a2	12	12
t	11	12
h1	95	127
h2	69	90
b	10	18
c	4	9
e	14	24
l	50	70
Weight	kg	kg
Al	0,32	1,05
Ms+Cu	0,97	3,15

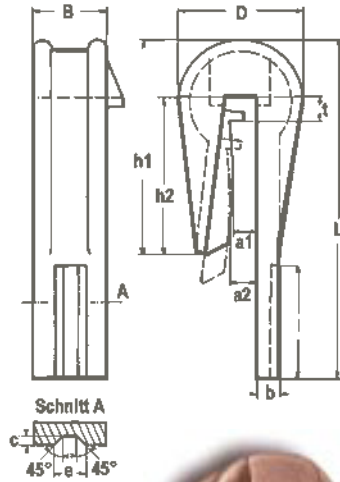

The ERKO® contact head is pushed onto the work or cathode rail from the top downwards. A clamping plate presses the contact surface of the head, via the wedge effect of the slideway guide, against the work rail, and thus establishes the non-positive contacting. The wedging can be easily released, either by the manual lever, which is pushed between the work rail and a lug provided on the contact head, or by with counter pressure alone.

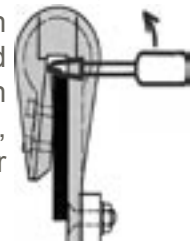

Quick-action contact head Type KK

Self-clamping Quick-action contact head for electroplating racks

Table of Dimensions in mm

Type	FK 30	FK40
Ampere	1000A	2000A
B	30	40
L	150	180
D	d+x+b	
x	Rail	
t	10	10
h1	82	103
h2	52	70
b	8	8
d	30	30
l	50	60
Weight	kg	kg
Ms+Cu	0,65	1,25

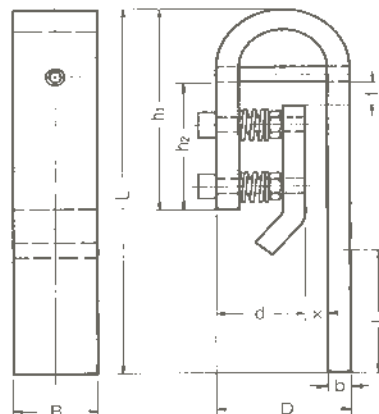

The ERKO® contact head FK is pushed onto the work or cathode rail from the top downwards. A flexible clamping plate presses the work rail against the contact surface of the head. The contact heads must be set for the individual work rail width. These should not exceed a tolerance range of above or below $\pm 0,5$ mm. The spring initial stressing force is not increased by an increase in the weight of the work carrier.